



The Economic Choice

EXS

Single Shaft Shredders



EXS Series Shredders

EconoGrind
the economic choice
EG2-190 (EG)

EconoGrind

the economic choice

Features and Benefits

- Specialized rotors with hardened alloys for demanding applications
- Sturdy ram construction that incorporates heavy duty guide bearings and universal couplings for reliable operation
- Standard serrated ram plate for processing large purging blocks and plates
- Standard feed hopper design allows bulk feeding via tipping skip as well as manual feeding of large bulky parts
- Square cutter blocks allow efficient cutting of material reducing heat build-up and degradation

Standard Description	EXS 1500	EXS 2000	EXS 3000
Large Capacity Hopper Feed Opening, in (mm)	100 x 63 (2540 x 1620)	100 x 79 (2540 x 2020)	100 x 111 (2540 x 2820)
Usable Open Area of Cutting Chamber, in (mm)	59 x 58 (1500 x 1490)	59 x 75 (1500 x 1900)	59 x 106 (1500 x 2700)
Standard motor in hp (kW)	2 x 100 HP (2 x 75)	2 x 100 HP (2 x 75)	2 x 150 HP (2 x 110)
Number of Rotor knives	76	96	136
Number of Bed Blades	4	5	7
Rotor Diameter, in (mm)	29.5 (750)	29.5 (750)	29.5 (750)
Rotor speed in rpm	54	54	54
Motor of Hydraulic device, hp (kW)	15 (11)	15 (11)	15 (11)
Screen Sizes Available, in (mm)	1-4 (20-100)	1-4 (20-100)	1-4 (20-100)
Mounted Knife-holders	Included	Included	Included
Hopper for manual/conveyor feeding	Included	Included	Included
Hydraulic feeding ram	Included	Included	Included
Two speed Turbo-Hydraulic	Included	Included	Included
Ram comb plate	Included	Included	Included
Control panel SPS	Included	Included	Included
Ampere-Meter in control cabinet	Included	Included	Included

Dimensions	EXS 1500	EXS 2000	EXS 3000
Length A, in (mm)	141.7 (3600)	141.7 (3600)	141.7 (3600)
Length B, in (mm)	102.4 (2600)	102.4 (2600)	102.4 (2600)
Length C, in (mm)	34.3 (870)	34.3 (870)	34.3 (870)
Length D, in (mm)	131.9 (3350)	131.9 (3350)	131.9 (3350)
Length E, in (mm)	99.9 (2540)	99.9 (2540)	99.9 (2540)
Width F, in (mm)	125.9 (3200)	154.7 (3930)	192.9 (4900)
Width G, in (mm)	63.7 (1620)	79.5 (2020)	111 (2820)

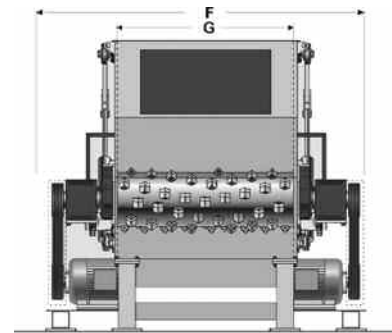
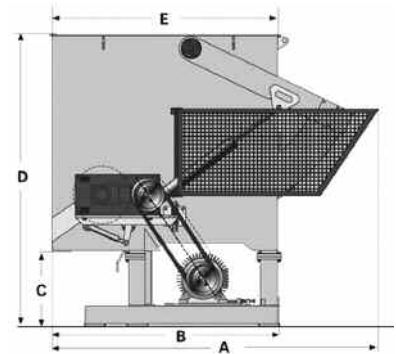

Equipment Sales

EconoGrind USA
300 Turner Street
South Attleboro, MA 02703-7900

Phone: 1 (508) 399-3018

Fax: 1 (508) 399-3150



Parts and Service

ACS Customer Service Group
Phone: 1 (800) 229-2919
Fax: 1 (508) 399-6306



Visit our website at www.econogrind.com. Please visit or call us anytime to discuss your recycling needs.